

VIEW "C-C"

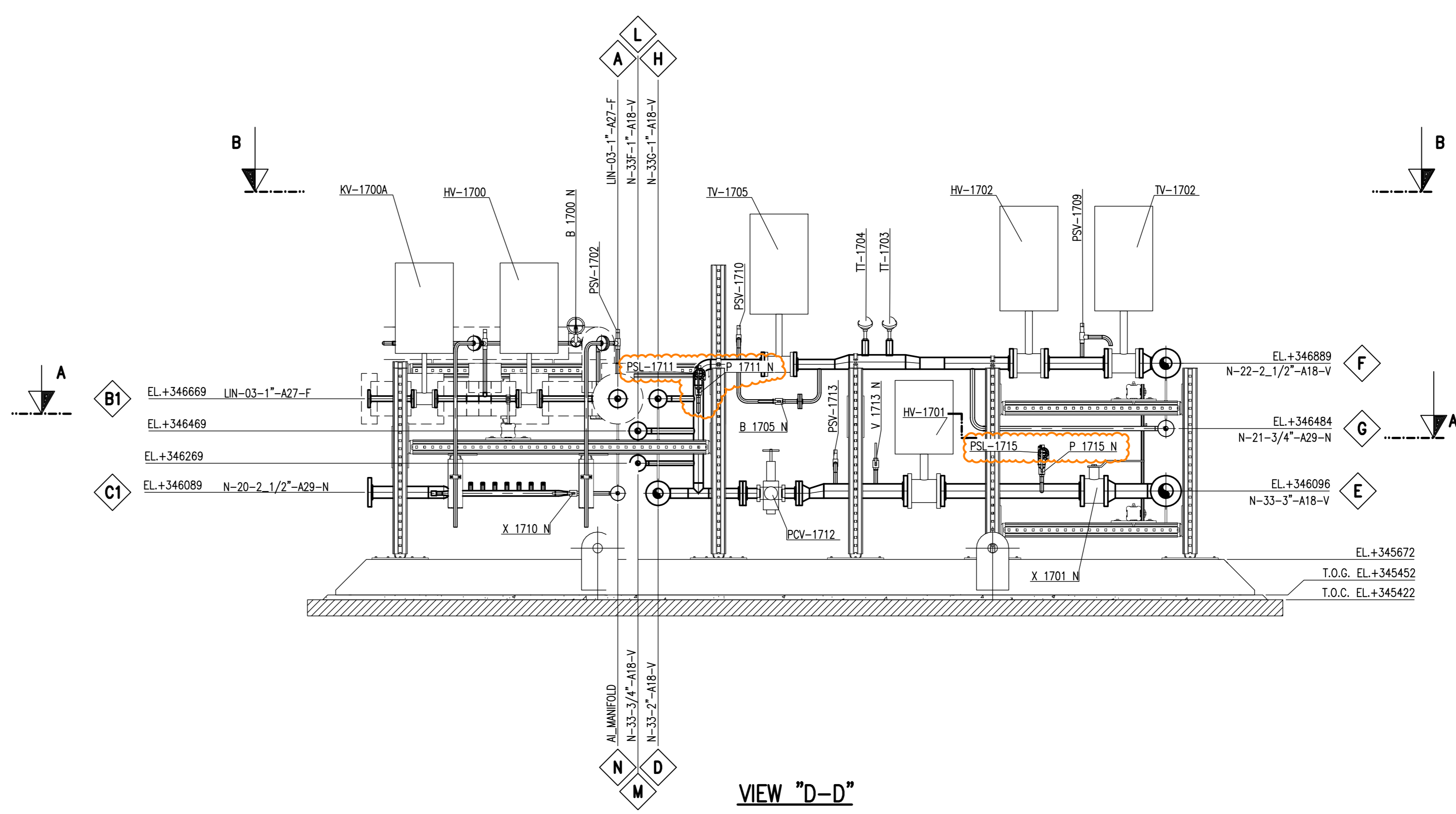

VIEW "D-D"

CONNECTION LIST			
	DESCRIPTION	LINE NUMBER	CONNECTION
A	NITROGEN INLET	LN-03-1"-A27-F	FLG. #1" 150# R.F.
B1	NITROGEN TO BACK-UP VAPORIZER (E17002A)	LN-03-1"-A27-F	FLG. #1" 150# R.F.
B2	NITROGEN TO BACK-UP VAPORIZER (E17002B)	LN-03-1"-A27-F	FLG. #1" 150# R.F.
C1	NITROGEN FROM BACK-UP VAPORIZER (E17002A)	N-20-2,1/2"-A29-N	FLG. #2,1/2" 150# R.F.
C2	NITROGEN FROM BACK-UP VAPORIZER (E17002B)	N-20-2,1/2"-A29-N	FLG. #2,1/2" 150# R.F.
D	NITROGEN OUTLET TO N2 RECYCLE COMPRESSOR AND TO COLD BOX	N-33-2"-A18-V	FLG. #2" 150# R.F.
E	INSTRUMENT NITROGEN TO PLANT (BACK-UP)	N-33-3"-A18-V	FLG. #3" 150# R.F.
F	NITROGEN FLUSHING TO PLANT (EMERGENCY ONLY)	N-22-2,1/2"-A18-V	FLG. #2,1/2" 150# R.F.
G	NITROGEN TO WARM/COLD TURBINE BOOSTER	N-21-3/4"-A29-N	FLG. #3/4" 150# R.F.
H	NITROGEN TO BOG COMPRESSOR	N-33-1"-A18-V	FLG. #1" 150# R.F.
L	NITROGEN TO NG REGENERATION COMPRESSOR	N-33-1"-A18-V	FLG. #1" 150# R.F.
M	NITROGEN TO LOADING BAYS	N-33-3/4"-A18-V	FLG. #3/4" 150# R.F.
N	INSTRUMENT AIR INLET	AL_MANIFOLD	FLG. #1/2" 150# R.F.

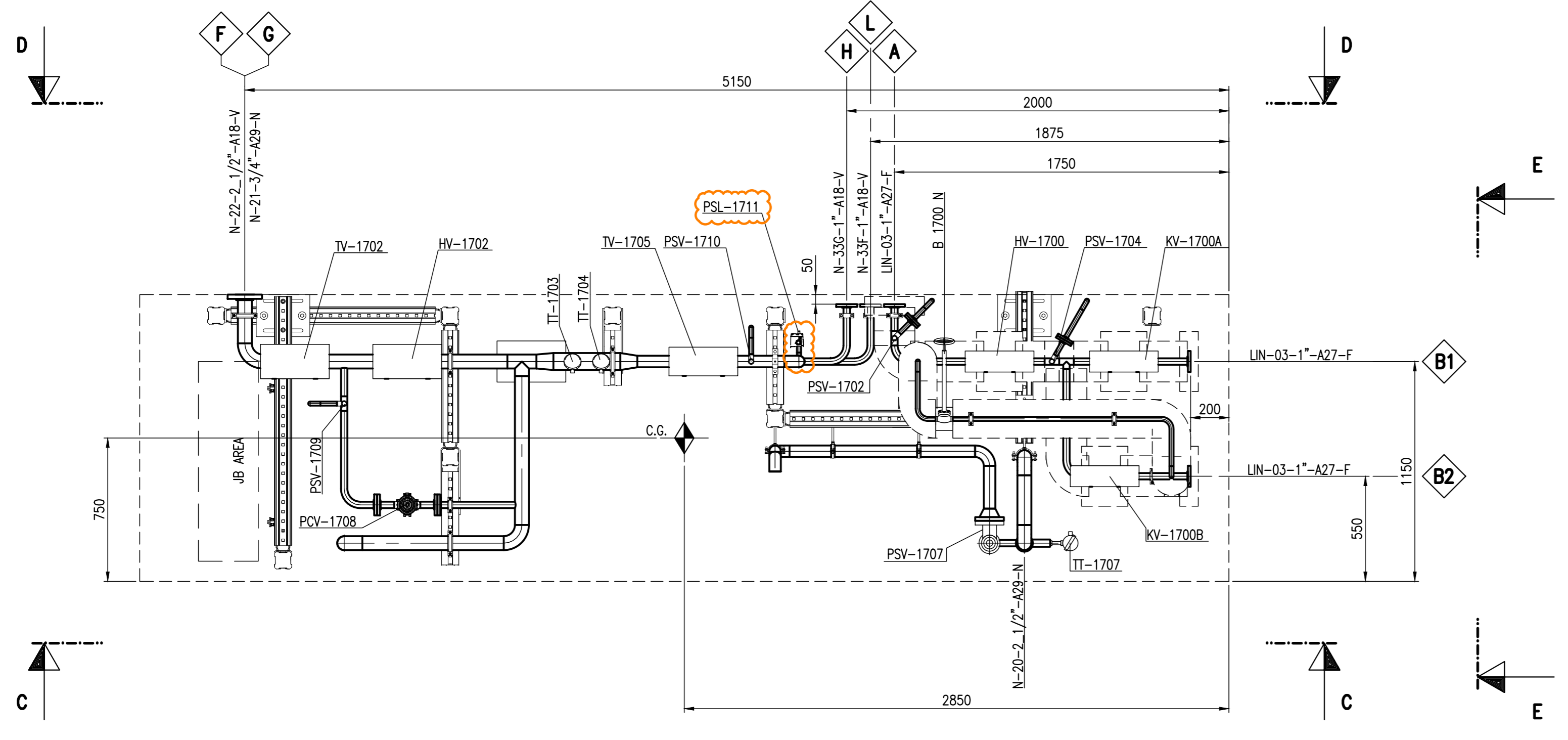

SECTION "B-B"

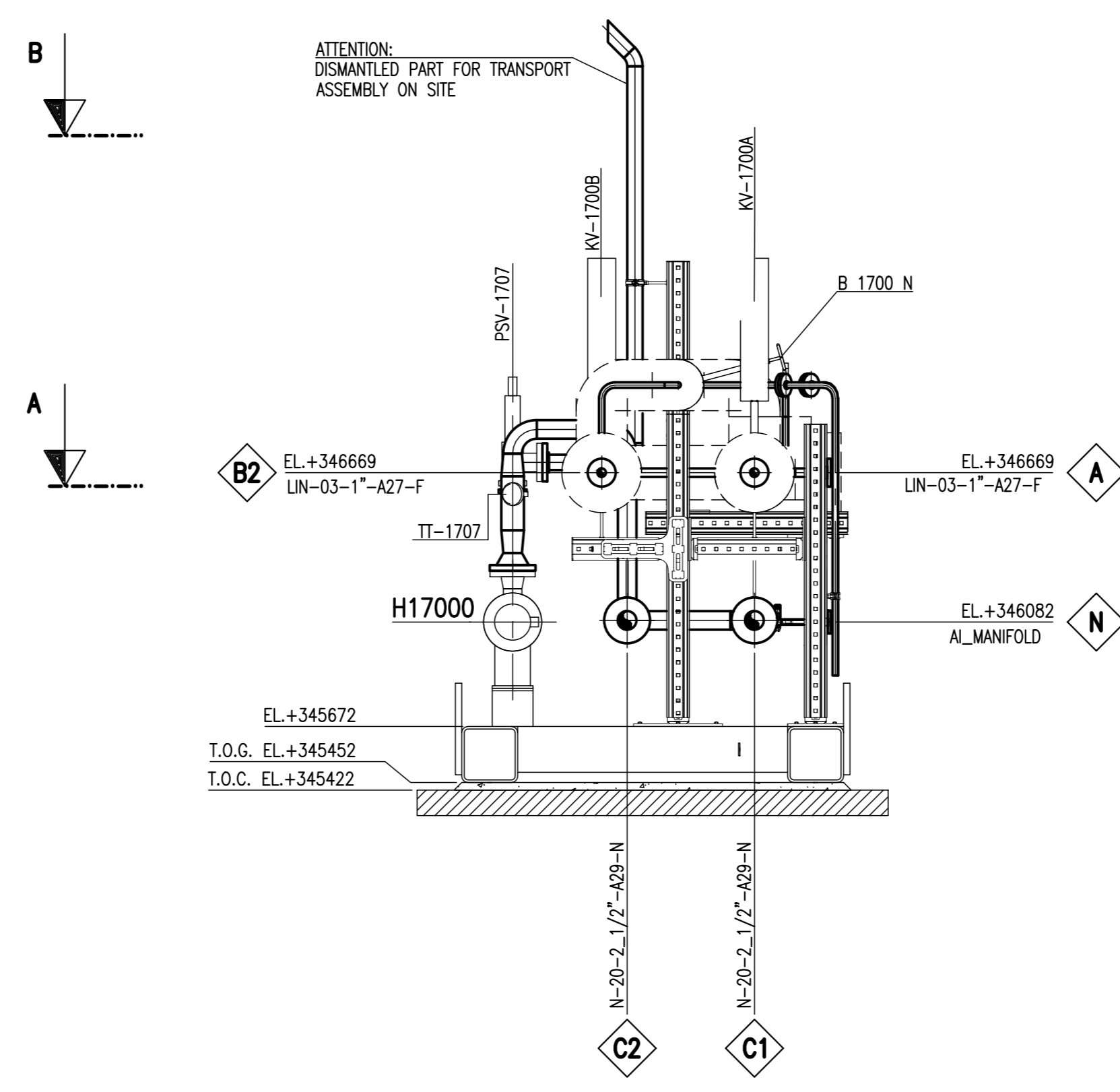

VIEW "E-E"

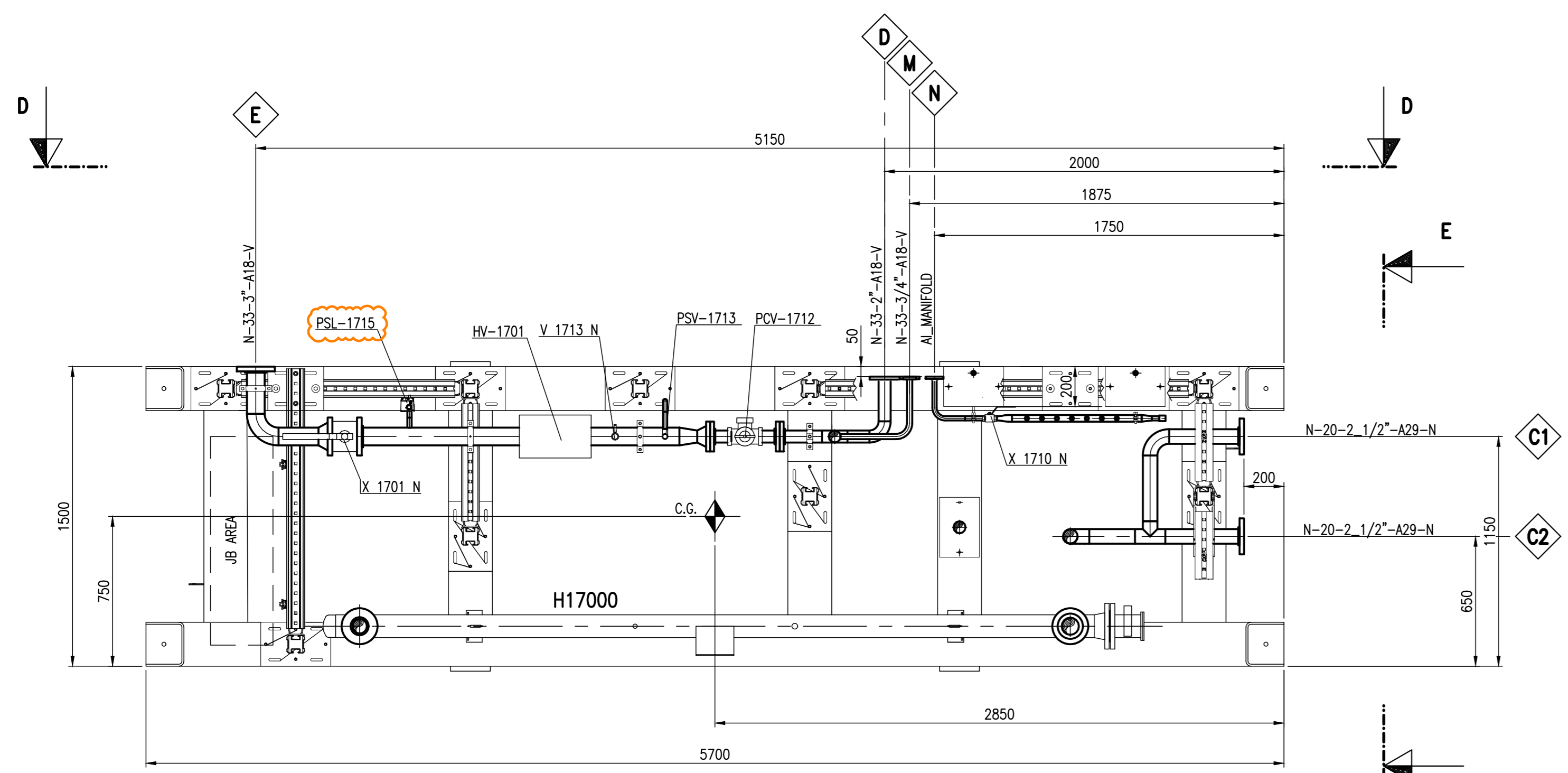
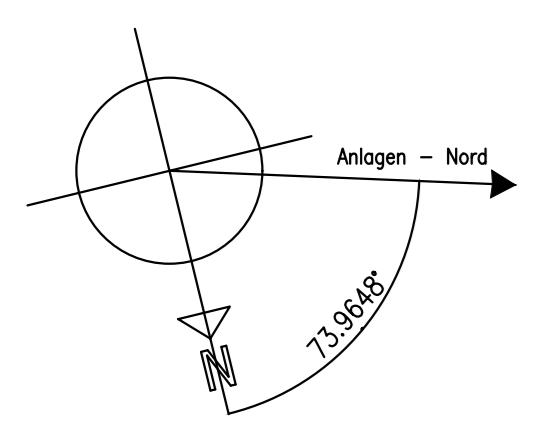

SECTION "A-A"

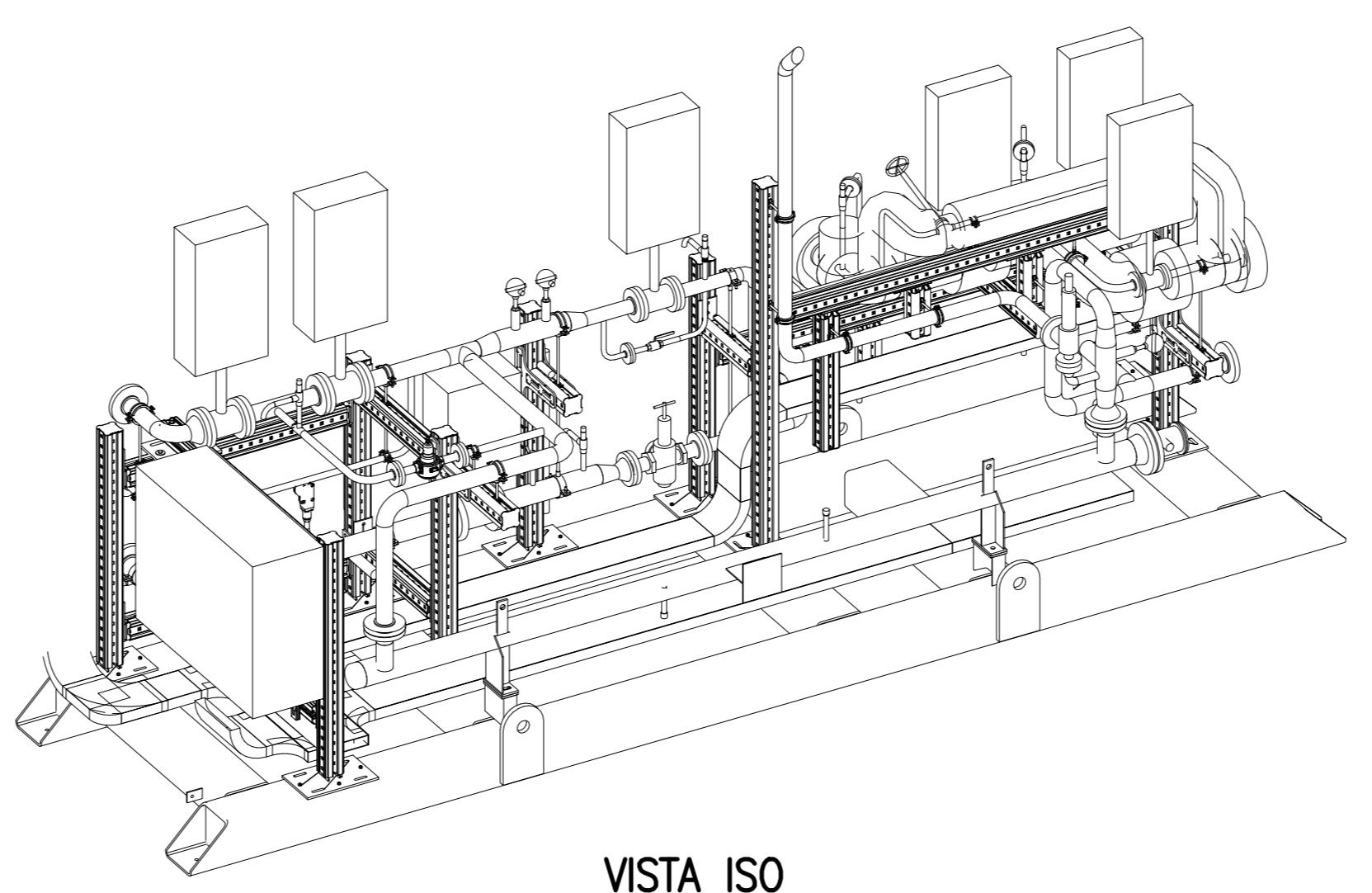

VISTA ISO

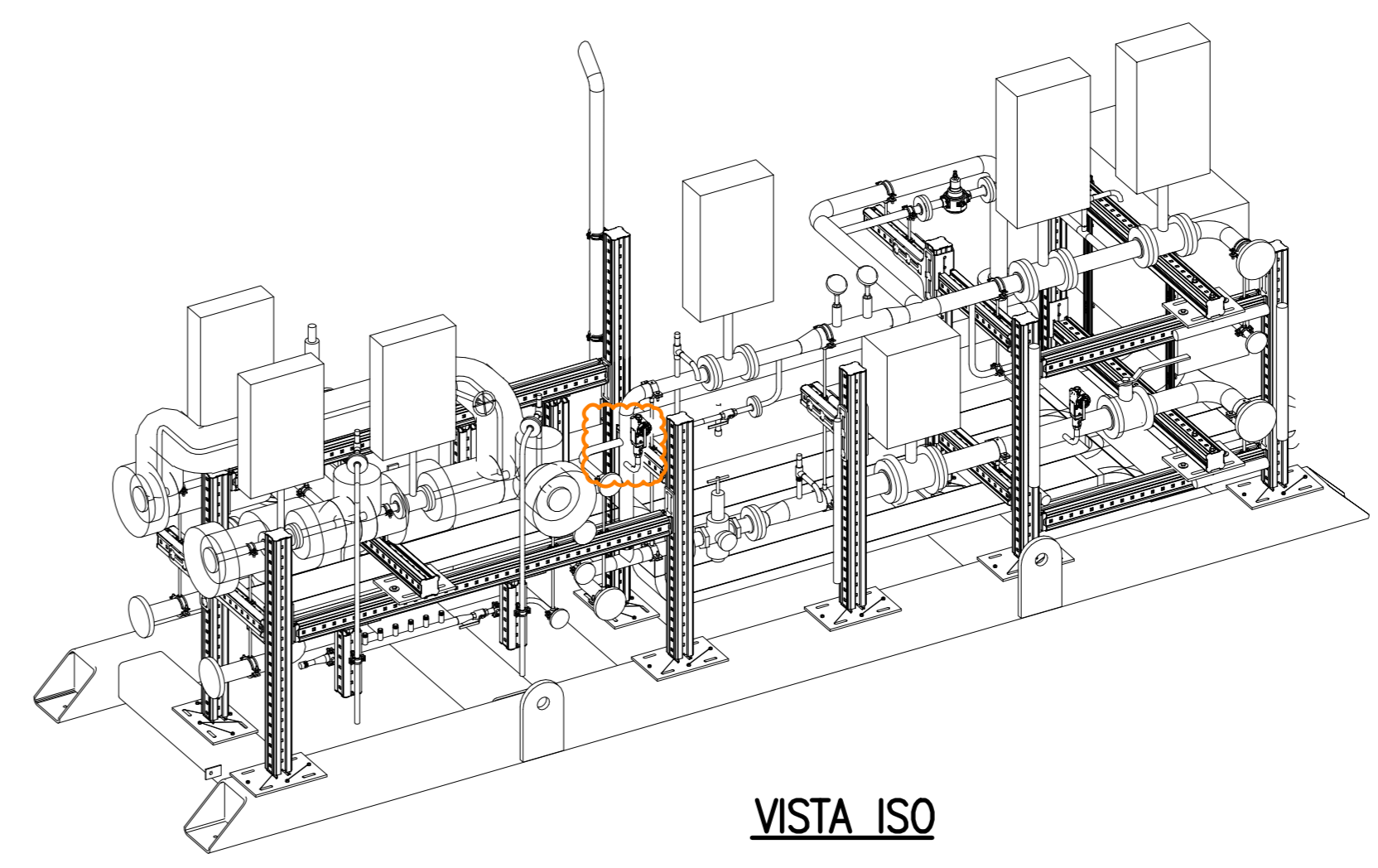

VISTA ISO

NOTE
 1. ALL DIMENSIONS ARE IN MILLIMETERS
 2. T.O.G. = TOP OF GROUT - T.O.C. = TOP OF CONCRETE

REF. DOCUMENTS
 • FOUNDATION LAYOUT WITH LOADS AND TRENCHES
 SEE DWG. I 20833 - 422REZH03001001PLY001

Rev	Datum	Bezeichnung	Standard	Profilname	Datum	Freigegeben
01	21.08.2023	REVISIÃO INDICADA	FERREIRA	OSCARINO	ANTONELLI	
02	21.08.2023	REVISIÃO INDICADA	GRITTM	OSCARINO	ANTONELLI	
03	21.08.2023	REVISIÃO INDICADA	LANGSTETTER	OSCARINO	ANTONELLI	
04	17.07.2023	REVISIÃO INDICADA E ALTERAÇÃO DE ELEVATION	GRITTM	OSCARINO	ANTONELLI	
05	21.08.2023	REVISIÃO INDICADA	ALVA	OSCARINO	ANTONELLI	
06	21.08.2023	REVISIÃO INDICADA	WISSE	OSCARINO	ANTONELLI	
07	21.08.2023	REVISIÃO INDICADA	WISSE	OSCARINO	ANTONELLI	
08	21.08.2023	REVISIÃO INDICADA	WISSE	OSCARINO	ANTONELLI	
09	21.08.2023	REVISIÃO INDICADA	WISSE	OSCARINO	ANTONELLI	
10	21.08.2023	REVISIÃO INDICADA	WISSE	OSCARINO	ANTONELLI	
11	21.08.2023	REVISIÃO INDICADA	WISSE	OSCARINO	ANTONELLI	
12	21.08.2023	REVISIÃO INDICADA	WISSE	OSCARINO	ANTONELLI	
13	21.08.2023	REVISIÃO INDICADA	WISSE	OSCARINO	ANTONELLI	
14	21.08.2023	REVISIÃO INDICADA	WISSE	OSCARINO	ANTONELLI	
15	21.08.2023	REVISIÃO INDICADA	WISSE	OSCARINO	ANTONELLI	
16	21.08.2023	REVISIÃO INDICADA	WISSE	OSCARINO	ANTONELLI	

Proj. No.	DG-001115	Standart	Profilname	LNG LIQUEFACTION PLANT
Datum	21.08.2023	Name	Zachungsbenennung	
Rev	01	Gründer		
Rev	02	ANTONELLI		
Rev	03	ANTONELLI		
Rev	04	ANTONELLI		
Rev	05	ANTONELLI		
Rev	06	ANTONELLI		
Rev	07	ANTONELLI		
Rev	08	ANTONELLI		
Rev	09	ANTONELLI		
Rev	10	ANTONELLI		
Rev	11	ANTONELLI		
Rev	12	ANTONELLI		
Rev	13	ANTONELLI		
Rev	14	ANTONELLI		
Rev	15	ANTONELLI		
Rev	16	ANTONELLI		