

SEC.A-A
FOOT PRINT DETAIL
(1 : 15)

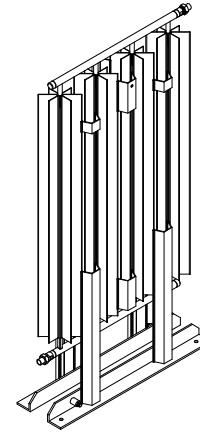

ISOMETRIC

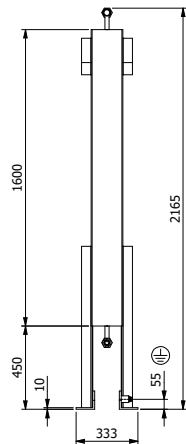

FRONT VIEW
(1 : 20)

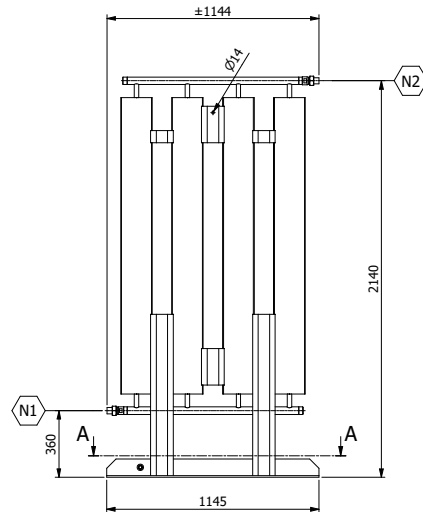

RIGHT SIDE
(1 : 20)

DESIGN DATA

ALLOWABLE MEDIA	O ₂ - N ₂ - Ar - CO ₂ - LNG
DESIGN PRESSURE	40 Barg
MAX. ALLOWABLE WORKING PRESSURE	40 Barg
TEST PRESSURE	58 Barg
NORMAL OPERATING PRESSURE	10-40 Barg
DESIGN TEMPERATURE	-196/+60°C
DESIGN CODE	EN13445 Ed. 2016
CERTIFICATION	PED 2014/68/EU

PRESSURIZED VOLUME	4,4 L
HEAT SURFACE AREA	10 m ²
UNIT WEIGHT, DRY	52 kg
MAX. UNIT WEIGHT, OPERATION	140 kg

GENERAL NOTES

- CLEANED FOR OXYGEN USE
- COUNTER FLANGES INCLUDED, MATERIAL 316/1.4401
- TOLERANCE ON DIMENSIONS ACC. TO NEN-ISO-2768-1/2-m
- PCS. EARTH BOSS M12 ON INSIDE OF FRAME LEGS
- CONCRETE FOUNDATION TO BE DESIGNED FOR DISPOSAL OF ICE AND MELT WATER

NOZZLE LIST

TP	QTY	DESCRIPTION	SIZE & RATING	TYPE
N1	1	LIQUID INLET	DN25-PN40	TYPE 2160900 3-PC COUPLING
N2	1	GAS OUTLET	DN25-PN40	TYPE 2160900 3-PC COUPLING

REVISIONS

REV	DESCRIPTION	BY	CHD	DATE
0	FIRST ISSUE, FOR REVIEW	AB		01-04-2021



ADPFORMED 3
2001 LH ALPHEM AFD RUM
THE NETHERLANDS
PHONE: +31 (0) 172 - 41 80 80
FAX: +31 (0) 172 - 43 88 18
WEB: WWW.CRYONORM.COM
EMAIL: SALES@CRYONORM.COM

THIS DRAWING IS THE EXCLUSIVE PROPERTY OF CRYONORM B.V. AND MAY NOT BE COPIED, MADE PUBLIC OR SHOWN TO THIRD PARTIES WITHOUT OUR WRITTEN CONSENT.



TITLE / DESCRIPTION
PB 1x4x1600
GENERAL ARRANGEMENT

DRAWN AB DOCUMENT NUMBER
DATE 31-3-2021

DRAWING/PART NUMBER

PB010401600-6-2525-1-111-0P0-A

SHEET
1 of 1

SIZE
A2

REV
0